

INNOVAIR

Intelligent Fan Convectors

Biddle



$$y = \frac{1}{2}x^2 + \frac{3}{2}x - 2$$

$$y = \frac{1}{2}(x^2 + 3x - 4)$$

$$y = \frac{1}{2}\left(x^2 + 3x + \frac{9}{4} - \frac{9}{4} - 4\right)$$

$$y = \frac{1}{2}\left(x + \frac{3}{2}\right)^2 - \frac{25}{4}$$

$$y = \frac{1}{2}\left(x + 1.5\right)^2 - 6.25$$

$$y = \frac{1}{2}(x + 1.5)^2 - 6.25$$

$$y = \frac{1}{2}(x + 1.5)^2 - 6.25$$

FRESH AIR FAN CONVECTORS

A lack of ventilation creates a stale and stuffy atmosphere that can lead to reduced concentration levels, headaches and nausea. Conventional means of introducing fresh air into buildings are usually uncontrolled and therefore not energy efficient. Innovair fresh air fan convectors provide controlled volumes of fresh air, control of space temperature and free/night cooling.

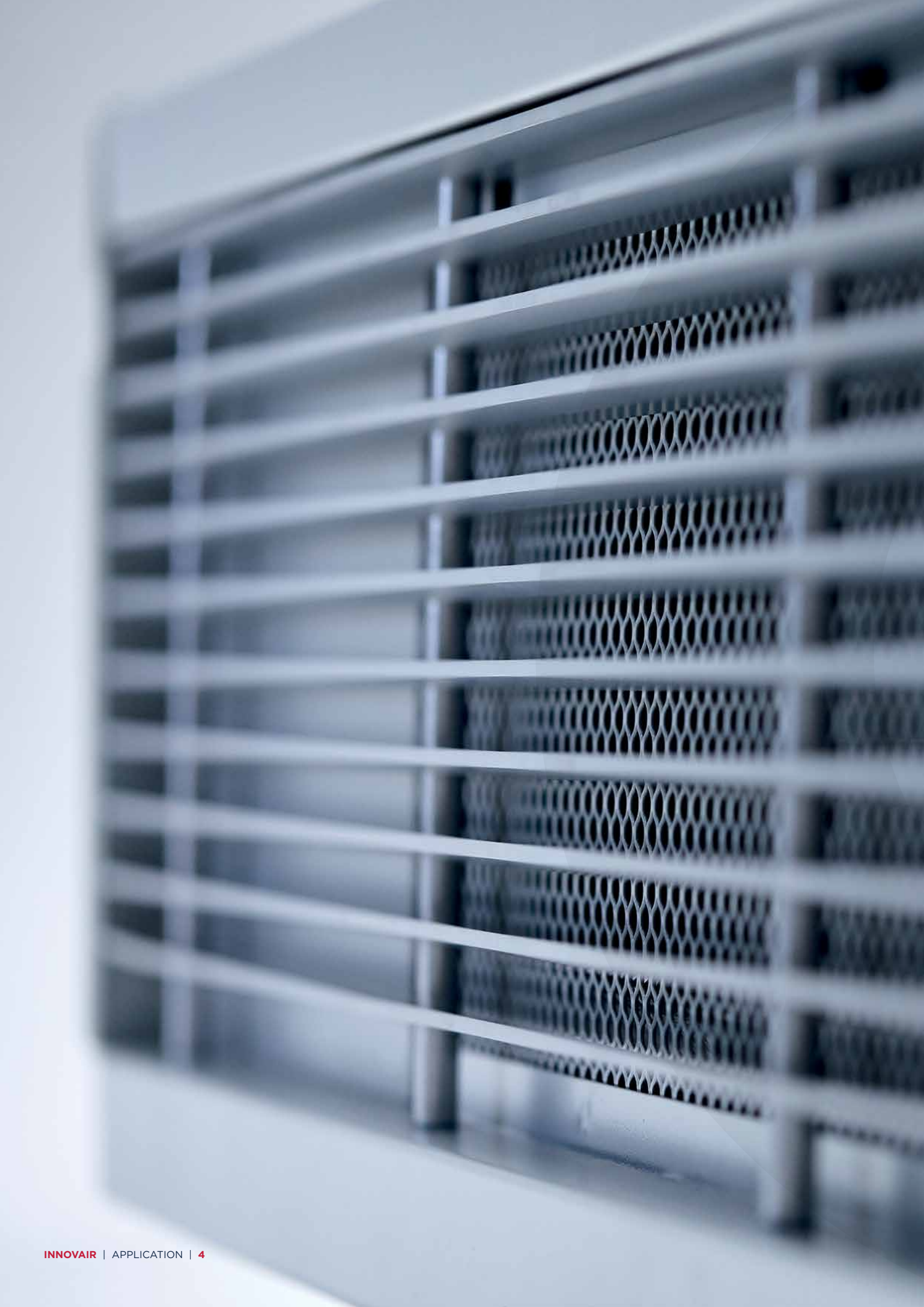

PATENTED DESIGN

All Innovair units incorporate a unique 'cyclic' fresh air damper system, which allows the amount of outside air entering the space to be accurately metered and varied in line with the occupants' fresh air requirements. With or without BMS control, one Innovair unit will heat and ventilate a typical room, occupied by up to 31 people.

Innovair is available in horizontal or vertical recessed/chassis or cased configurations. It has also been specifically developed to meet the requirements of all the regulations covering heating and ventilation equipment in schools.

The patented 'cyclic' fresh air damper system provides precise quantities of outside air for ventilation (BB101), free cooling and night cooling. It is also available with high efficiency fans operating at a specific fan power of <math><0.2\text{W/l/s}</math>.

FEATURES AND BENEFITS:

- Natural ventilation capability
- Control of space temperature using LPHW
- Controlled volumes of fresh air, heated as necessary using LPHW
- Free and night cooling

HOW IT WORKS

Based upon a conventional fan convector with a filter, fan(s) and heating coil within a sheet metal casing with discharge and return air spigots/grilles, it's patented 'cyclic' fresh air damper system provides precise quantities of outside air for the purposes of ventilation (BB101 calls for 8 l/s per person), free cooling and night cooling.

Each unit has high efficiency 4-pole AC fans operating at a specific fan power of <math><0.40\text{W/l/s}</math>, which is considerably less than the maximum specific fan power of 0.8W/l/s (which is stipulated in Part L2A and Part L2B of the Building Regulations) and operates at 90W and will consume 0.72kWh during an 8 hour day, or 3.6kWh during a typical working week.

Incorporating a Trend IQeco35 microprocessor controller with Bacnet BMS capability, enabling the unit to:

- Control the space temperature, by heating or free cooling against an adjustable set-point using a P+I control loop
- Supply a metered quantity of outside air, via a 'cyclic' damper system, to vary ventilation levels in line with occupancy levels
- Carry out night cooling following periods of high daytime heat gain to remove excess heat from the space, cool the building fabric and maintain thermal comfort during the following day

Provide a BMS capability with Trend Control Systems Ltd networks including:

- On/off timetabling with optimum start
- Trend logging
- Remote control of occupied and un-occupied set-point temperature
- Control of a group of units using an averaged outside air temperature
- Remote control of outside air supply



AIR COMFORT CONTROL

CONTROLLING SPACE TEMPERATURE

All Innovair units incorporate a set-point temperature adjuster, a space temperature sensor, an outside air temperature sensor and a discharge temperature sensor. The readings from these sensors are continually 'fed back' to each unit's Trend IQL15+ programmable controller. Each unit also incorporates a 4-port valve/ actuator and four single speed fans, both controlled by the Trend IQL15+ controller.

The valve/actuator and fans are then controlled depending on the difference between the set-point and space temperatures. Assuming the natural ventilation capability is enabled, if comfort conditions cannot be maintained through natural ventilation the fans will run and do not turn off once set-point temperature is achieved. This ensures that space temperature is maintained in an energy efficient manner.

During unoccupied periods (typically overnight) when the boiler is turned off the unit will operate in 'set back' mode, with the low limit temperature cut out thermostat detecting the lack of hot water and turning the fans off. In contrast, during the summer months when the boiler is turned off the summer/winter switch (supplied by Biddle) can be used to keep the fans running and circulate fresh air.

CONTROLLING FRESH AIR VOLUMES

All Innovair units incorporate a patented 'cyclic' fresh air damper system allows the amount of outside air entering the space to be accurately metered and varied in line with occupants' fresh air requirements.

The damper blade is set by the controller to either the fully open, or fully closed. As the total air volume flow rate is known the controller can set the time the damper is in the fully open position and therefore accurately meter the quantity of fresh air. The more fresh air that is required the more of the 6 minute cycle time the blade is in the fully open position, and vice versa. The problem of draughts normally occurs when fresh air terminal units are overcome as the damper blade moves quickly between the fully open and fully closed positions.

The proportion of outside air drawn in by the unit is controlled, depending whether the unit is for Non-BMS or BMS control, using either a CO₂ sensor (supplied by Biddle) to vary fresh air levels in line with occupancy or a BMS through the LON Works communications bus (requiring on site programming and commissioning by a designated controls specialist).

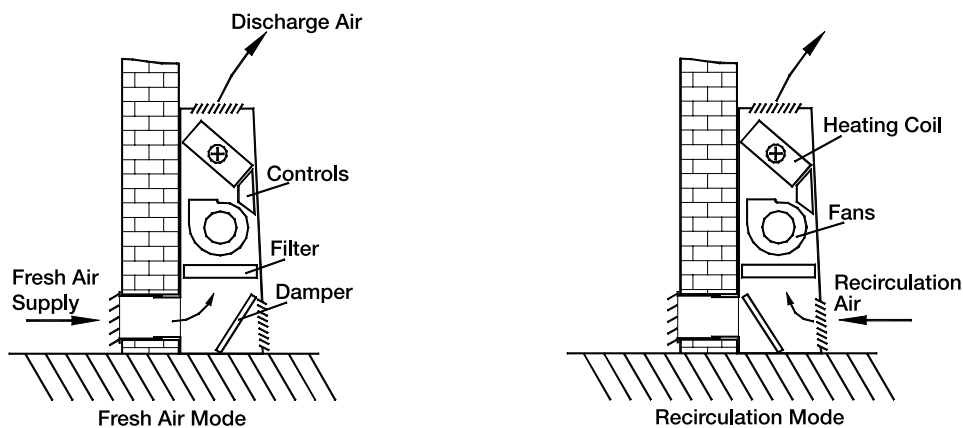



NATURAL VENTILATION

With a Non-BMS control Innovair (when the fresh air volume is controlled using the CO₂ sensor) can be operated as a Mixed Mode (Hybrid) system, taking advantage of natural ventilation. In such a situation the fans do not run if room temperature and CO₂ levels are satisfied, the damper is open and natural ventilation forces the outside air supply through the unit and into the room.

Whilst units are supplied with this passive natural ventilation feature disabled, it can be enabled by removing a 'wiring link' within the unit. It can then be switched on or off using a switch (supplied by Biddle).

FREE AND NIGHT COOLING

As well as providing controlled ventilation in line with the regulations Innovair will utilise fresh air to provide free and night cooling when appropriate. This is particularly beneficial in the summer when cooler night time air can be used to cool the building fabric and offset daytime overheating.

MECHANICAL COOLING

Whilst Innovair is not designed to provide mechanical cooling it has been established that, using a 2-pipe change-over system, low grade chilled water (such as that from a ground source heat pump chiller) can be used to achieve some mechanical cooling during the summer months.

In particular it can be used to augment the night cooling effect and act as a 'coolth' depository if it is necessary to recharge ground heat during the summer when using a ground source heat pump for winter heating. As Innovair does not have a drain tray, to ensure there is no condensation formation on the coil, chilled water flow temperatures must be 14°C or above.

Indicative mechanical cooling outputs, using the low output coil, are:

Entering air temperature	Chilled water flow/return temperatures	Cooling output (kW)	Water flow rate (l/s)	Combined coil + valve pressure drop (kPa)
25°C/50% rh	14/18°C	1.7	0.106	13.4
	15/18°C	1.6	0.137	22.1
	15/19°C	1.5	0.093	11.6

SPECIFICATIONS

CHASSIS/CASING

Manufactured from 20gauge (1.0mm thick) zinc coated steel which is folded, welded and riveted together to form a rigid and solid structure with a smooth epoxy polyester powder paint finish in RAL9018. Cased units incorporate end panels of rigid, high impact ABS plastic painted in RAL7033.

COIL

Each 2 row coil, comprises a single block constructed from copper tubes with mechanically bonded aluminium fins. The copper headers are fitted with a 1/8" BSP hexagonal air vent. Coils are leak tested to 30 bar. A 4-port valve is factory fitted to the coil.

DAMPER ACTUATOR AND BLADE

Having been tested over 500,000 cycles (equating to 15 years of normal use) the actuator comprises a motor and gearbox operating against a minimum torque of 3 Nm and is powered by a mains voltage signal from the controller. The damper blade is manufactured from a rigid 'Foamex' material and seals tightly against the fresh air opening.

CONTROLLER

Each unit incorporates a Trend IQL15+ controller which has been pre-programmed with Biddle's bespoke Innovair control algorithm.

FANS

Each unit has double-inlet, double-width centrifugal fans, each complete with an integral direct drive 4-pole AC motor with thermal protection. The high specification motors are 'sealed for life' and anti-vibration mounted to give an expected life in excess of 40,000 running hours. EC/DC fans are available as an option.

FILTERS

Each unit contains four individual cardboard frame EU3 grade panel filters, positioned to filter both outside fresh air and internal recirculation air.

ACCESS

The fans and filters can be accessed and removed via the panel, secured with two 'hex head' fasteners, on the front of the unit.

INSULATION

The unit chassis/casing and the attenuator are lined with self-adhesive class 'O' foam insulation which assists in attenuating extraneous noise.

ACOUSTIC PERFORMANCE

SOUND POWER SPECTRUM

Recessed							
	63Hz	125Hz	250Hz	500Hz	1kHz	2kHz	4kHz
Inlet/casing radiated (dB 10-12W)	43.5	54.1	49.6	47.3	43.2	34.1	26.3
Discharge (dB 10-12W)	43.9	52.1	49.7	47.1	42.9	33.1	25.2
Cased							
Total (dB 10-12W)	40.0	42.5	44.2	42.1	37.1	26.0	16.3

To ensure good acoustic performance:

- The return air grille(s) in the ceiling should be positioned at least 2m away from the return air inlet of the unit
- Any false ceiling should be of a good acoustic grade, comprising compressed mineral fibre tiles in a tight fitting 'T' grid, with the total ceiling system having a Sound Reduction Index (SRI) and tile face Absorption Coefficient (α) as follows:

Minimum acoustic properties of false ceiling							
Freq (Hz)	63	125	250	500	1000	2000	4000
SRI (dB)	7	9	10	15	20	24	27
α	0.50	0.75	0.70	0.65	0.85	0.85	0.80

The outside air inlet needs to have the attenuation insertion losses as below.

Outside air inlet - minimum attenuation insertion losses							
Freq (Hz)	63	125	250	500	1000	2000	4000
Lw (dB)	1	3	11	17	17	12	11

This is achieved using the attenuator integral to the Innovair and reduces an exterior noise level of 60dBa at the facade (based on the typical traffic noise spectrum in an inner city environment) to the 35dBa (LAeq,30min) classroom noise level required by BB93 and BB101.

PERFORMANCE DATA

CASED UNITS (IE. OPA EXTERNAL RESISTANCE) CHASSIS UNITS (IE. 20PA EXTERNAL RESISTANCE)

NR level	Total air volume (l/s)	LPHW flow & return temp* (°C)	Heating output (kW) EAT = 20°C	Leaving air temp (°C) when EAT = 20°C	Heating output (kW) EAT = -3°C	Leaving air temp (°C) when EAT = -3°C	Water flow rate (kg/s)	Combined coil + valve pressure drop (kPa)	Valve Size
31	246	82/62	11.03	57	15.70	46	0.134	17.9	15mm, 1.6kvs
		80/60	10.52	55	15.22	44	0.128	17.4	
		70/50	8.20	48	12.41	36	0.100	10.6	
		60/45	6.74	42	10.93	31	0.108	11.7	
		60/40	5.91	40	9.50	27	0.071	5.7	
		55/40	5.52	39	9.50	26	0.089	8.9	
		55/35	4.70	36	7.90	21	0.056	3.9	

*The water flow rate should be that required to achieve the heating output with EAT = 20°C. The heating output when EAT = -3°C is calculated at this water flow rate, and the water return temperature will be lower than that shown. For example with a water flow temperature of 70°C the water return temperature with an EAT of -3°C and a water flow rate of 0.100 kg/sec will be 40°C rather than 50°C

SPECIFIC FAN POWER

The 4 pole ac fans in Innovair operate below the 0.8W/l/s specific fan power requirement of Part L2A and L2B of the latest Building Regulations.

Configuration	Specific fan power
Cased	0.32 W/l/s
Chassis	0.40 W/l/s

ENERGY CONSUMPTION

- ⦿ A chassis Innovair operates at 90W, consuming 0.72kWh during an 8 hour day
- ⦿ A cased Innovair operates at 72W, consuming 0.58kWh during an 8 hour day

Both configurations require a single phase power supply and have a running current of 1.5 amps.

EC/DC FANS

If optional EC/DC fans are used then specific fan powers are reduced to 0.15W/l/s and 0.20W/l/s for the cased and chassis configurations respectively. A chassis Innovair, with EC/DC fans, operates at 45W consuming 0.36kWh during an 8 hour day.

DIMENSIONS CASED UNITS

INNOVAIR MODEL WF2

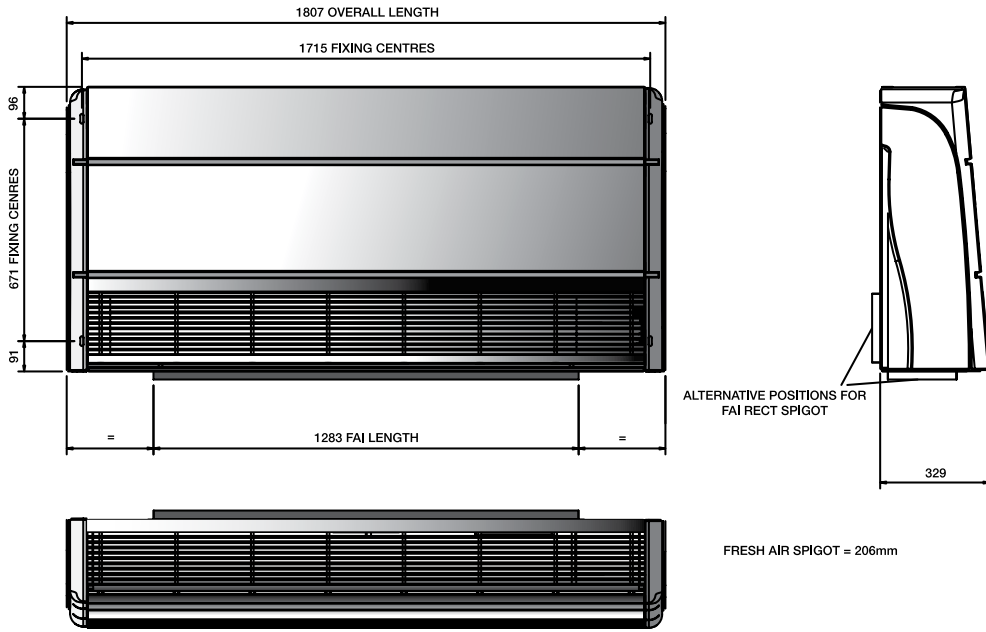

INNOVAIR MODEL CF2

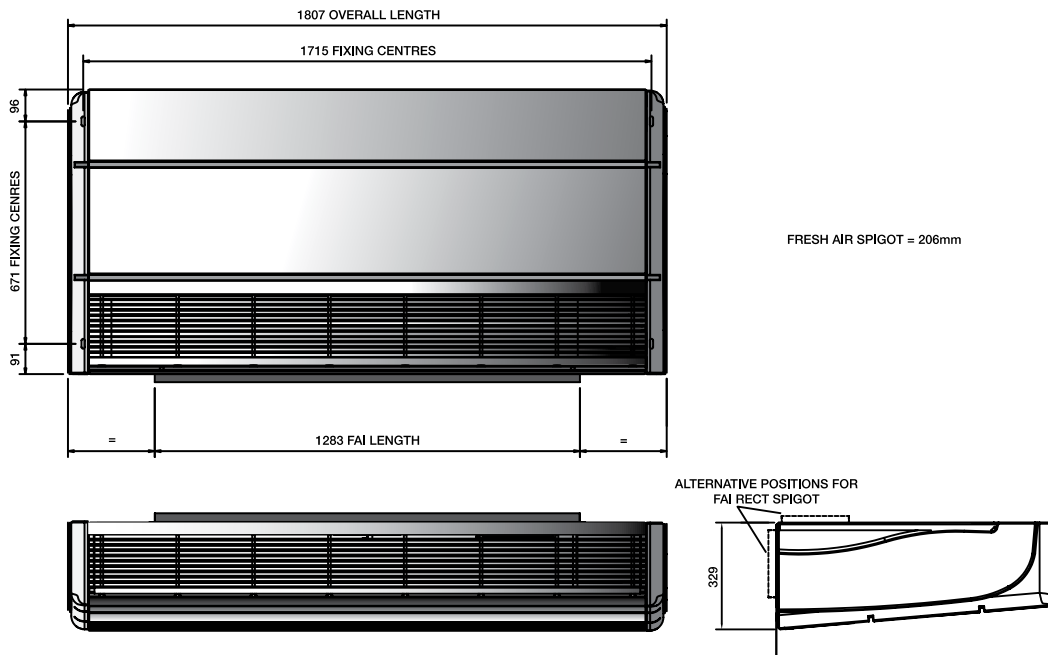

DIMENSIONS CHASSIS UNITS

INNOVAIR MODEL WL2

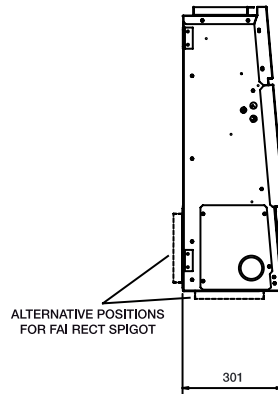
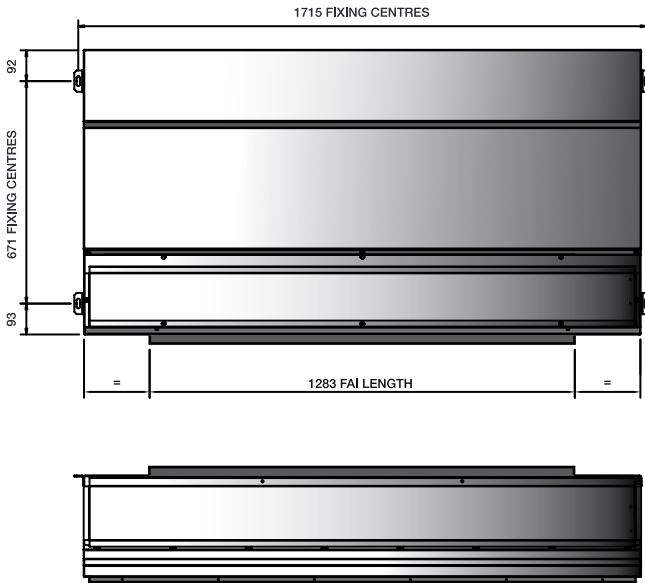

FRESH AIR SPIGOT = 206mm
DISCHARGE & RETURN AIR SPIGOT = 162mm

INNOVAIR MODEL CL2

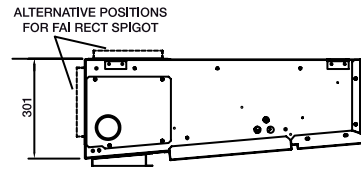

FRESH AIR SPIGOT = 206mm
DISCHARGE & RETURN AIR SPIGOT = 162mm

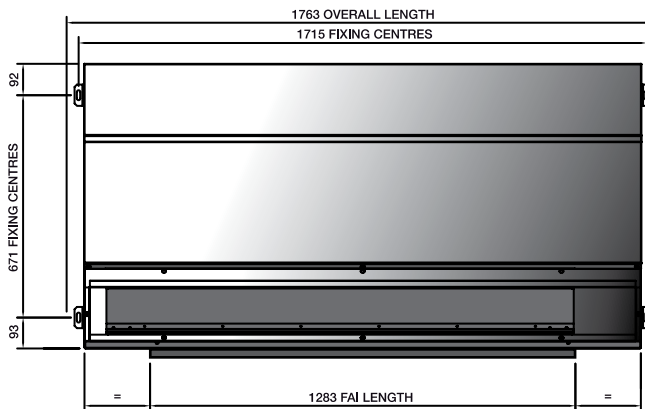

DIMENSIONS

FAI LINING INNER AND OUTER WITH ACOUSTIC LINING

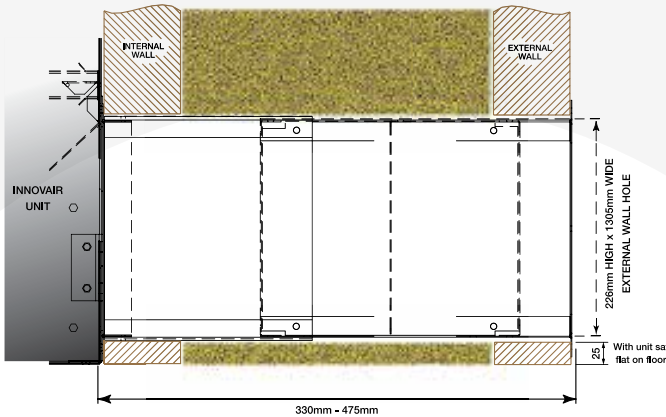

On chassis units state whether rectangular or circular spigots are required.

The fresh air spigot / inlet is always rectangular.

UNIT WEIGHTS

○ Cased = 99kg ○ Chassis = 94kg

MODEL REFERENCE

The model reference consists of a code giving unit size, coil and casing arrangement.

W3V - **WL2SCH**



WIRING DIAGRAMS

CONNECTING AN EXTERNAL FAN OR VENTILATION SYSTEM

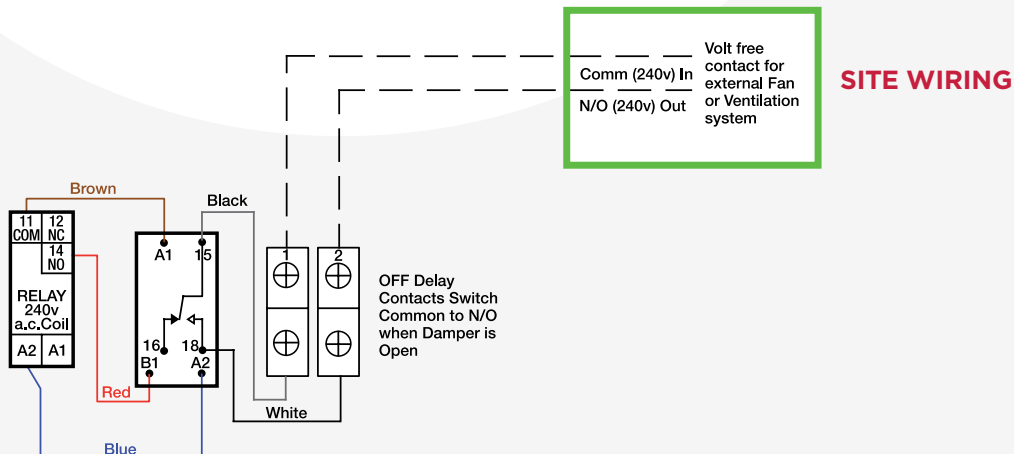

CONNECTING TB/TS/K WALL PAD

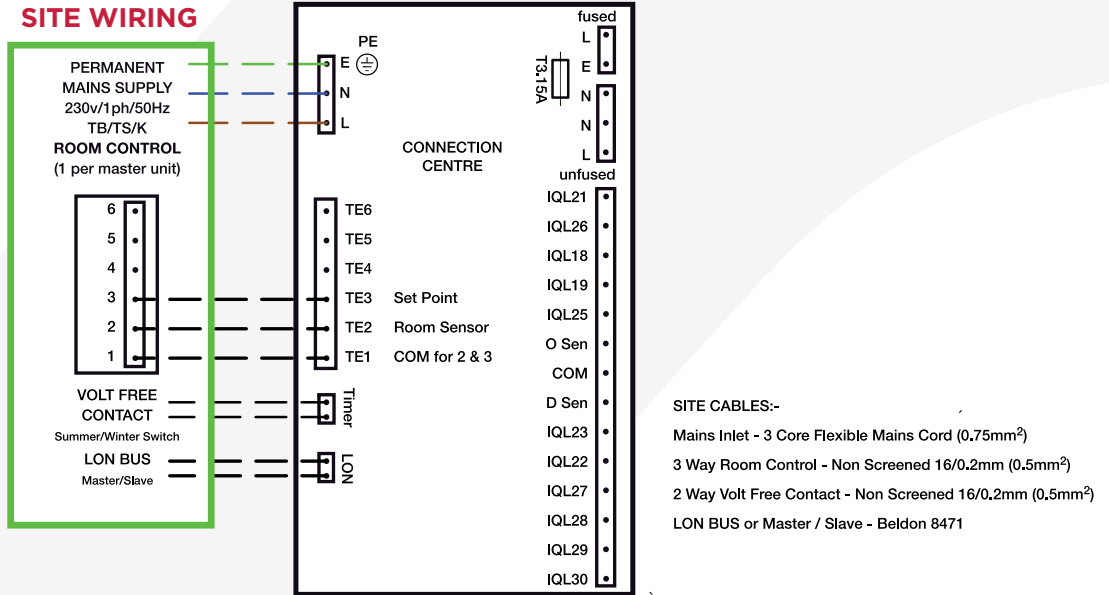

CONNECTING CO₂ SENSOR, LOW LIMIT WATER PIPE THERMOSTAT & NATURAL VENTILATION SWITCH

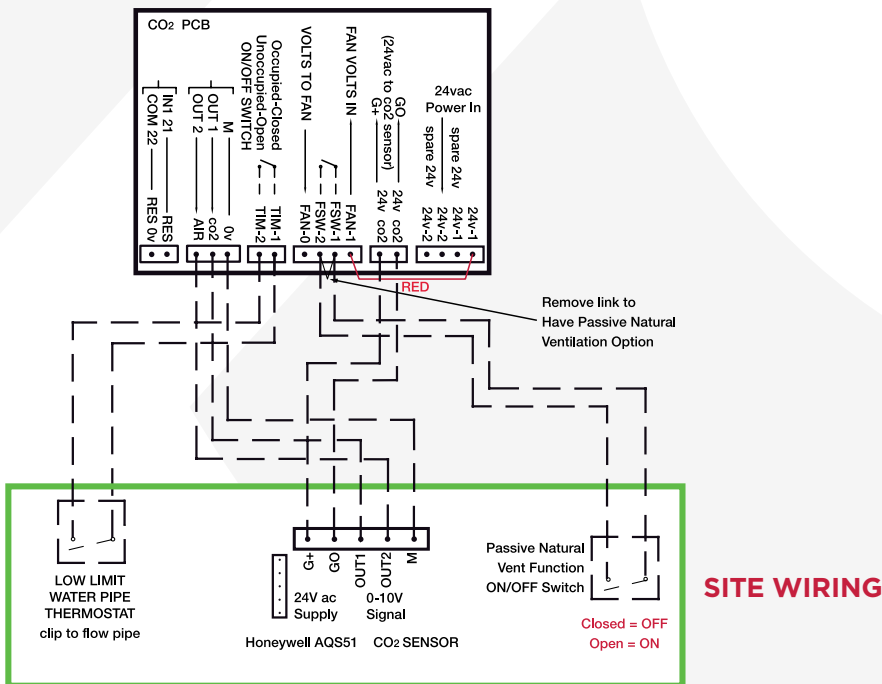

CO₂ SENSOR 24v SUPPLY - Non Screened 16/0.2mm (0.5mm²)

CO₂ SENSOR SIGNAL - Screened 16/0/0.2mm (0.5mm²)

BIDDLE AIR SYSTEMS

St. Mary's Road
Nuneaton
Warwickshire
CV11 5AU

T +44 (0) 2476 384 233

E sales@biddle-air.co.uk

www.biddle-air.co.uk



Biddle

Every effort has been made to ensure descriptions are correct at the time of print.
Errors and omissions excepted. INNOVAIR|V1|09|2019