

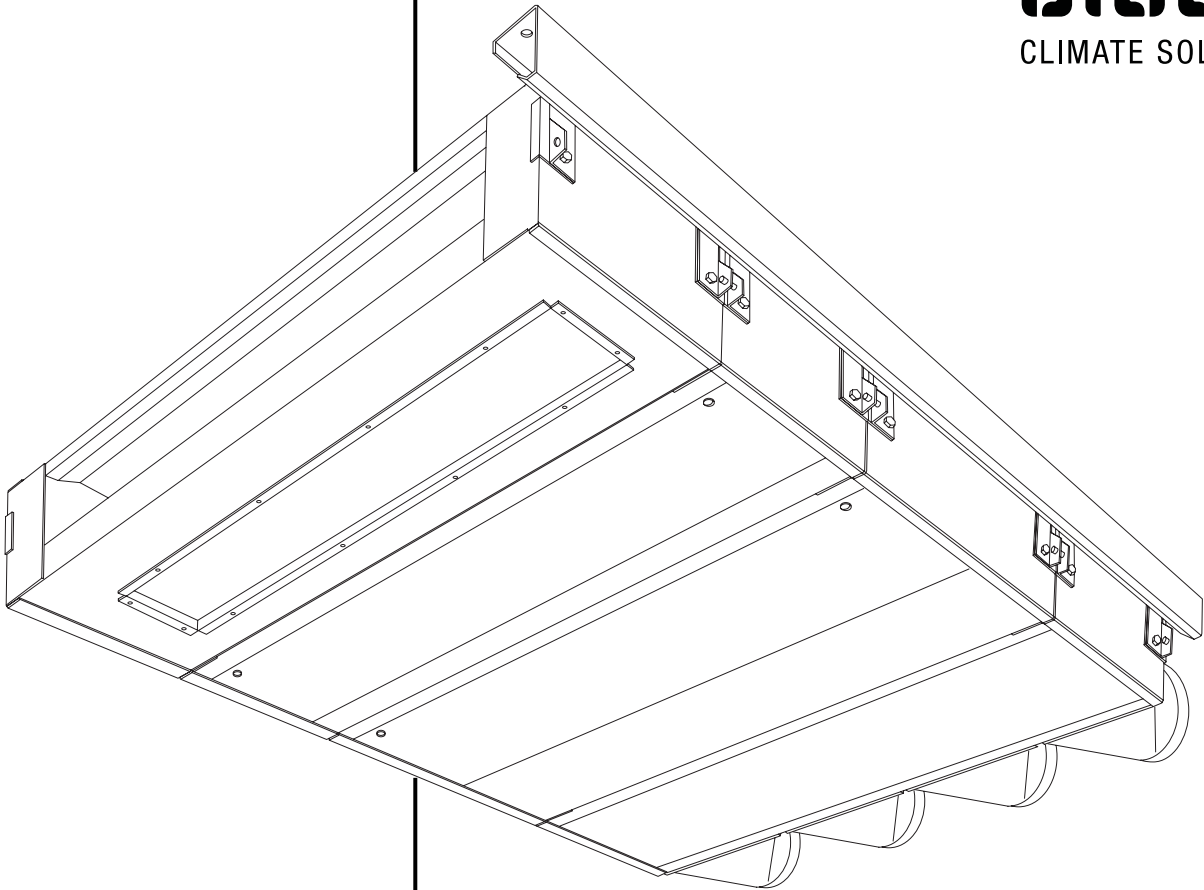

biddle

CLIMATE SOLUTIONS



Manual

Modular fan coil unit
Model **PS**

Version 2.1

17-07-2018

English



Copyright

All the information and drawings in this manual are the property of Biddle and may not be used (other than for the actual operation of the device), photocopied, duplicated, translated and/or be brought to the attention of third parties without Biddle's prior written permission.

The name Biddle is a registered trademark.

Trademarks

The name Biddle is a registered trademark of Biddle bv.

Warranty and liability

Please refer to Biddle's Terms of Sales and Delivery for warranty and liability conditions.

Biddle excludes liability for consequential loss at all times and under all circumstances.

Liability for the contents of this manual

However much care might have been taken in ensuring the correctness and, where necessary, completeness of the description of the relevant parts, Biddle disclaims all liability for damage resulting from any inaccuracies and/or deficiencies in this manual.

Should you detect any errors or ambiguities in this manual then we would be pleased to hear from you: it helps us to improve our documentation even further.

Biddle retains the right to change the specifications stated in this manual.

For more information

If you have any comments or questions about specific topics relating to this product, please do not hesitate to contact Biddle.

Addresses

United Kingdom

Biddle Air Systems

St. Mary's Road

Nuneaton

Warwickshire CV11 5AU

United Kingdom

telephone: 024 7638 4233

fax: 024 7637 3621

e-mail: sales@biddle-air.co.uk

internet: www.biddle-air.com

Other countries

Biddle Export

PO Box 15

NL-9288 ZG Kootsterille

The Netherlands

telephone: +31 512 335555

fax: +31 512 335554

e-mail: export@biddle.nl

internet: www.biddle.info

Contents

1 Introduction	4	2.7 Connecting the valve motor	12
1.1 About this manual	4	2.8 Connecting ducts	12
1.2 How to use this manual	4	2.9 Connecting the unit to the CH and/or CW system	12
1.2.1 Marginal symbols in the manual	4	2.9.1 Water connections	12
1.2.2 Pictograms used on the unit and in the manual	4	2.9.2 Frost protection	13
1.2.3 Related documentation	4	2.9.3 Connecting water pipes	13
1.3 About the unit	5	2.10 Connecting the condensate drain ..	13
1.3.1 Applications	5	2.10.1 Particulars	13
1.3.2 Working	5	2.10.2 Connecting the condensate drain ...	13
1.3.3 Modules	5	2.11 Connecting the unit to mains power supply	14
1.3.4 Type code	6	2.11.1 General	14
1.3.5 Type plate	6	2.11.2 Connecting to mains	14
1.4 Components	6	2.12 Installing the controller	14
1.4.1 Required components	6	2.13 Switching on and checking operation	14
1.4.2 Accessories	7		
1.4.3 Parts not supplied	7	3 Maintenance	16
1.5 Safety instructions	7	3.1 Safety instructions	16
1.5.1 Operation	7	3.2 Replacing the filter	16
1.5.2 Installation, maintenance and service	7	3.2.1 Introduction	16
		3.2.2 Replacing flat-bed filter in base module	16
2 Installation	8	3.2.3 Replacing bag-type filter or pleated filter	16
2.1 Safety instructions	8	3.3 Cleaning	16
2.2 Delivery check	8	3.4 Scheduled maintenance	16
2.3 General instructions	8		
2.3.1 Order of working	8	4 Service	18
2.3.2 Miscellaneous	8	4.1 Safety instructions	18
2.4 Installing the wall duct	8	4.2 Opening the unit	18
2.5 Installing the roof duct	9	4.2.1 Base module	18
2.6 Suspending the unit	10	4.2.2 Electronics compartment	18
2.6.1 Positioning	10	4.3 Fuses	19
2.6.2 Installing the suspension rail	10	4.4 High-limit thermostat	19
2.6.3 Suspending and securing modules ...	11		

1 Introduction

1.1 About this manual

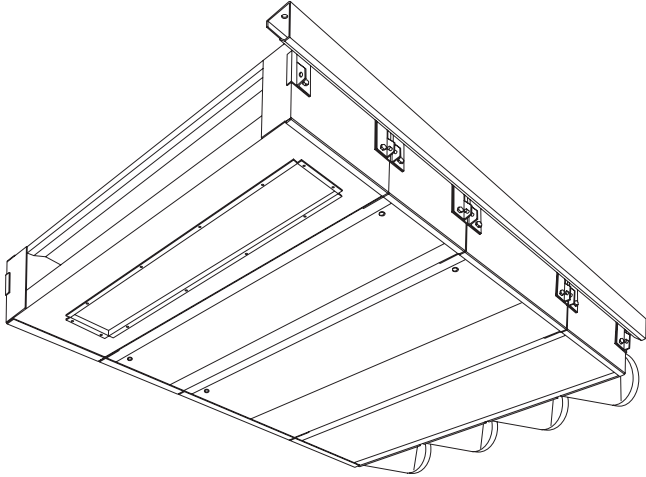

This manual describes the installation and maintenance of the modular fan coil unit, model **PS**.

This manual only relates to the unit itself. A separate manual covers the operation and control of the unit.

1.2 How to use this manual

1.2.1 Marginal symbols in the manual



Note:

Draws your attention to an important part of the text.



Caution:

If you do not carry out this procedure or action correctly, you may damage the unit.

So, follow the instructions carefully.



Warning:

If you do not carry out this procedure or action correctly, you may cause material damage and/or physical injury.

So, follow the instructions carefully.



Danger:

This indicates actions which are not permitted. Ignoring this warning may lead to serious damage or accidents that may involve physical injury.

For units with ... :

With ... module:

The description applies only to models that have the feature referred to.

If no specific model is referred to, the description applies to all models.

1.2.2 Pictograms used on the unit and in the manual

The below pictograms refer to possible risks or dangers. These pictograms can also be found on the unit.

	<p>Warning: You are entering an area which contains live components. Accessible to qualified maintenance staff only. Caution is urged.</p>
	<p>Warning: This surface or part can be hot. There is a risk of burns on contact.</p>

1.2.3 Related documentation

Besides this manual, the following documents come with the unit:

- documentation for control and operation (if applicable);
- wiring diagram for installation and service purposes.

1.3 About the unit

1.3.1 Applications

The modular fan coil unit is designed for heating, cooling and/or ventilating rooms. The inlets and outlets of the unit are positioned in such a way that the discharged air flow is distributed evenly across the room without causing discomfort to the people in it. The unit's dimensions are geared to integrating the unit in suspended ceilings.

1.3.2 Working

The fan coil unit blows a flow of air into the room. The air may be taken in, at the user's option, either from outside (ventilation) or from the room itself (recirculation). Thus, the unit offers two benefits:

- The room is kept at the desired temperature.
- Gradual deterioration of air quality in the room is counteracted.

1.3.3 Modules

A modular fan coil unit is made up of modules. Each module has its specific function. By combining different modules, modular fan coil units with different features can be composed.

Type references and symbols of modules

PS B	base module	
PS P	plenum module	
PS F	filter module	
PS FP	pleated filter module	
PS L	air valve module	
PS G	attenuation module	
PS V	heating module (water)	
PS VE	heating module (electric)	

The symbols can be found on the underside of each module. On the base module, these symbols indicate the order of the modules of the delivered modular fan coil unit.

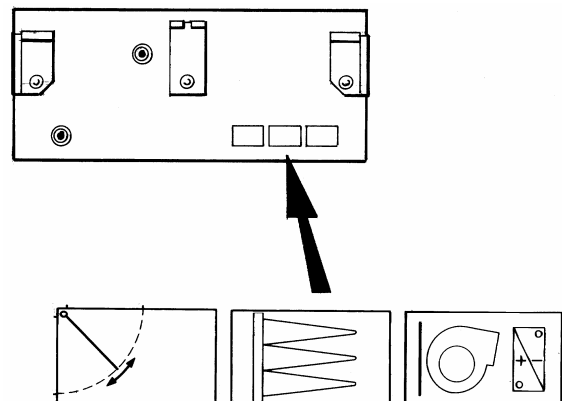

1.3.4 Type code

The type references, when combined, constitute the type code of the unit's modules, for instance:

PS B-20-H1-M
PS P-21
PS G-40
PS V-61-H1C3-I



Various combinations can be made.

Explanation of type code

series	PS	modular fan coil unit
module	B, P, F, FP, L, G, V, VE	see <i>Section 1.3.3</i>
capacity	20, 21, 40, 41, 60, 61	
with base module and/or heating module: heating and/or cooling	H1, H2, H3, H4	water heating
	C3, C4	water cooling
	H1C3, H2C2	water heating and cooling
	HE	electric heating
with base module: electronic control	M	modulating control
	S	speed control
	I	<i>Interface</i> , either with or without touch control
	B	<i>Basic</i> , without control
	<i>without reference</i>	<i>not described in this manual</i>

1.3.5 Type plate

The type plate is located on the base module.

 Biddle bv Markowei 4 NL-9288 HA Kootstertille 	Type	PS B-40-H2-M		
	Code	4023	U	230 V ~ 50 Hz
	N°	123456/1-1 07-12	I _{max} L1	0.88 A
			I _{max} L2	-
	M	51 kg	I _{max} L3	-
	Medium	LPHW	P _{motor}	0.20 kW
	p _{max} 600 kPa	P _{heating}	-	

Example of a type plate

References on the type plate

Type	full type code of unit
Code	if applicable: unit code of electronic control
M	weight of unit
P_{max}	with water heating: maximum allowable operating pressure
U	supply voltage
I_{max}	maximum amperage
P_{motor}	maximum power absorbed by fans
P_{heating}	with electric heating: maximum power absorbed by heating

1.4 Components

1.4.1 Required components

The following components are delivered separately but are always required:

- mounting kit, consisting of a suspension rail and fasteners for linking modules
- electronic control system components, such as a controller, control cables, etc. (see the documentation of the control system)

1.4.2 Accessories

The following optional accessories are available:

- water control unit
- servomotor for air valve module
- ventilation module for the control of an extractor fan
- wall sleeve
- external air intake grille
- roof cap
- duct connection (**PS TH** and **PS TV**)
- flexible connection sleeves, with or without connecting flange
- wall and ceiling grilles, fixed or adjustable
- condensate drain tray
- condensate discharge pump

1.4.3 Parts not supplied

The following parts are not supplied by Biddle and should be procured from other suppliers:

- threaded suspension rods (M8)
- mounting rail

1.5 Safety instructions

1.5.1 Operation



Warning:

Do not put any objects in the inlets and outlets.

Do not block the inlets and outlets.



The upper surface of the unit can become hot during operation.

1.5.2 Installation, maintenance and service



Warning:

The unit may be opened by qualified technical staff only.



Before opening the unit:

- Switch the unit **off** using the controller.
- Wait until the fans have stopped rotating.
- Allow the unit to cool down as the heat exchanger or heating element can get very hot.
- Disconnect the mains supply.
- Shut off the CH and/or CW supply (if possible).



Warning:

The fins of the heat exchanger are sharp.

2 Installation

2.1 Safety instructions



Warning:

Installation works may be performed by qualified technical staff only.

Before opening the unit, follow the safety instructions in Section 1.5.

2.2 Delivery check

- Check the unit and its packaging for correct delivery. Report any transport damage to the driver and supplier immediately.
- Make sure that all parts and components have been supplied (see Section 1.4). Report any defects to the supplier immediately.

2.3 General instructions

2.3.1 Order of working

Biddle recommends following the order of working described in this section for performing the installation works.



Note:

Make sure you perform all operations that are required for the installation of your unit. Check the type plate and refer to Section 1.3.5 if you are not sure about the model or type of your unit.

2.3.2 Miscellaneous



Caution:

The infiltration of coarse dust, cement, etc. may damage the unit. So long as such contaminants are in the room,

- do not put the unit into operation;
- cover the inlets and outlets.

2.4 Installing the wall duct

Accessory, only in combination with air valve module (PS L)

The wall duct is made up of a wall sleeve and an external air intake grille. The wall duct is made up of two parts which are slid into one another.

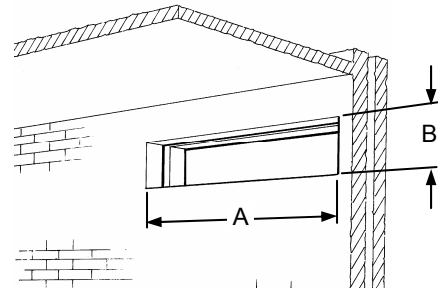

Opening dimensions for wall duct

type	opening, A x B	wall thickness
PS 20, 21	628 x 142 mm	200 – 350 mm
PS 40, 41	1003 x 142 mm	or 350 - 650 mm
PS 60, 61	1503 x 142 mm	(dep. on type)

- 1 Apply the included expanding foam gasket around the ventilation opening of the air valve module.
- 2 Make an opening in the wall.

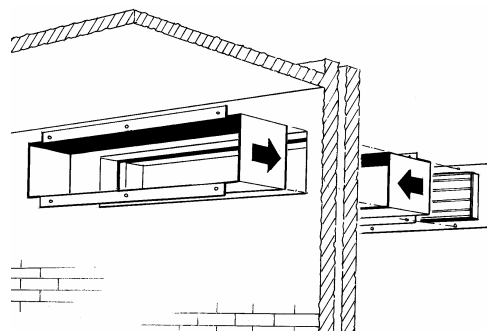

- 3 Fix the duct sections as you please, e.g., by bricking them in or by fixing them with screws. If using screws, mind their positions: the screws must not hinder the installation of the external grille.



Note:

Seal any gaps between sleeve and wall in a draught- and leakage-free manner.

- 4 Drill the (∅ 5mm) grille fixing holes into the flanges of the sleeve section that is fixed to the outer wall.
- 5 Apply paste onto the inner side of the grille flanges. The paste is to seal off the gap between grille and sleeve in a draught- and leakage-free manner.
- 6 Fix the grille to the flanges using sheet metal screws.

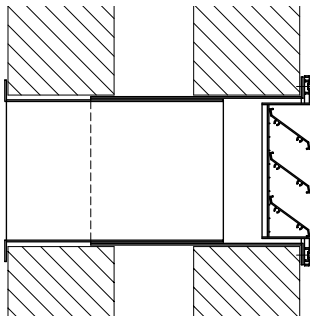

Caution:

Place the grille with the blades correctly positioned: oriented outward to allow for run-off.

2.5 Installing the roof duct

Accessory, only in combination with air valve module (PS L)

The roof duct is made up of two parts: a roof curb and a roof cap. The roof cap consists of a cover and a sleeve. On delivery, these are attached to one another.

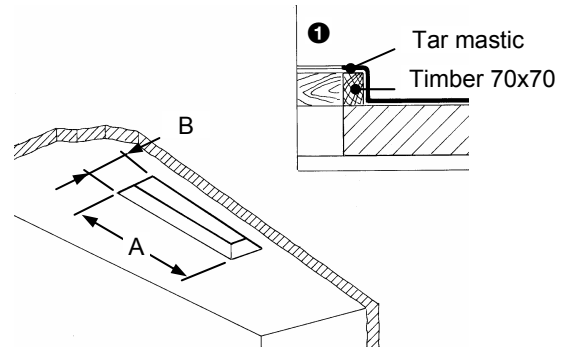

Opening dimensions for roof duct

type	opening, A x B
PS 20, 21	628 x 145 mm
PS 40, 41	1003 x 145 mm
PS 60, 61	1503 x 145 mm

- 1 Apply the included expanding foam gasket around the ventilation opening of the air valve module.
- 2 Make an opening in the roof.
- 3 Make a water-tight curb ❶ around the opening.
- 4 Detach the cap from the sleeve. To do so, loosen the screws in the upper side of the sleeve.

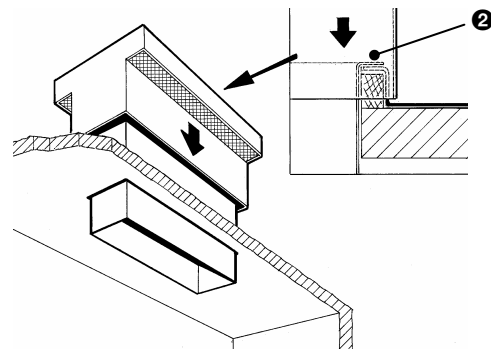

- 5 Insert the sleeve into the opening. Connect sleeve and curb by fixing screws ❷ through the sleeve's inner side.
- 6 Mount the cap to the sleeve.



Note:

Seal any gaps between sleeve and roof in a draught- and leakage-free manner.

2.6 Suspending the unit

2.6.1 Positioning

- Make sure that the structure from which the modules are to be suspended can carry the weight of the whole modular fan coil unit.

Module weights

	PS 20, 21	PS 40, 41	PS 60, 61
PS B	32 kg	51 kg	62 kg
PS P	8 kg	10 kg	12 kg
PS F, FP	10 kg	13 kg	16 kg
PS L	13 kg	16 kg	20 kg
PS G	18 kg	24 kg	31 kg
PS V, VE	15 kg	19 kg	22 kg

- Suspend the unit at a minimum height of 1.8 m.
- Suspend the modules level. This results in proper venting of the heat exchanger and (for units with cooling) in proper discharge of condensate.
- Provide for proper sealing if wall or roof sleeves and the like are installed. Improper installation can cause draught and condensate problems.
- Ensure the air can flow freely through the unit's inlets and outlets.
- Position the unit such that the modules will be easy to access both during and after installation.

2.6.2 Installing the suspension rail

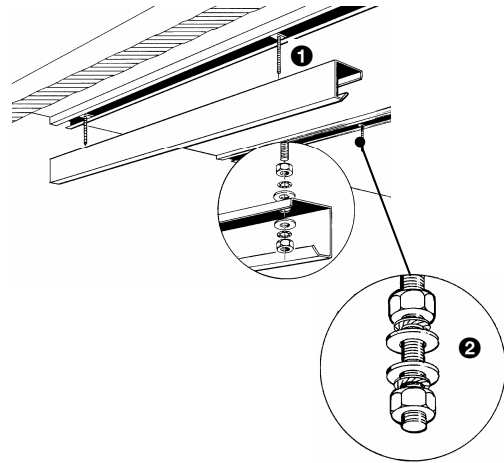

The modules are hooked into the included suspension rail on one side. On the opposite side (connection side), the modules are suspended from a thread rod. The suspension rail may either be suspended from a thread rod ❶ (as illustrated above) or be mounted directly onto the ceiling (as illustrated below).

- 1 Make a suspension structure using thread rods, mounting rails and the supplied suspension rail. On each thread rod, apply two nuts at an intermediate distance of about 4 cm ❷.

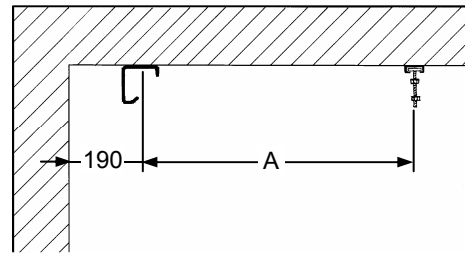

Centre distance between mounting rails and suspension rails

	PS 20, 21	PS 40, 41	PS 60, 61
A	782 mm	1157 mm	1657 mm



Note:

- Keep a minimum distance of 190 mm between the centre of the suspension rail and a wall or obstacle, such as a pillar. This is to allow the modules to be hooked in.
- Mount the rails in line with a possible opening for a roof or wall sleeve.

2.6.3 Suspending and securing modules

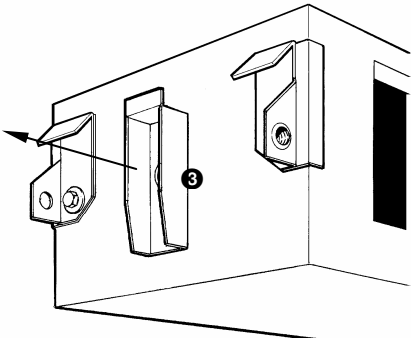

- 1 The base module (PS B) and the attenuation module (PS G) are provided with a securing bracket ③. Remove it.

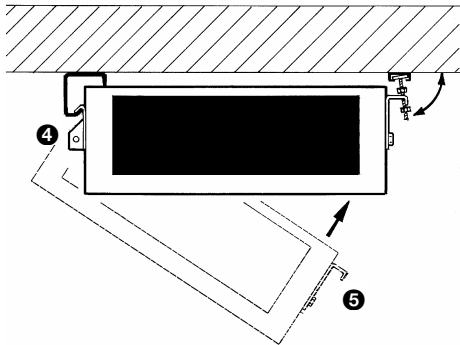

- 2 Hook the modules into the suspension structure one by one. Hook the suspension brackets ④ into the suspension rail on the one side, and the suspension hook ⑤ in the thread rod on the other side.

In suspending the modules, follow the order that is indicated in the schedule on the base module (see Section 1.3.3).

- 3 Using the thread rods, adjust the modules vertically so that they are level.

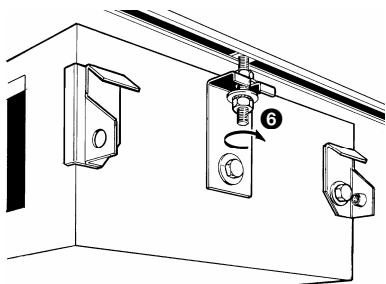

- 4 Secure the suspension hook ⑥ between the two nuts on the thread rod.

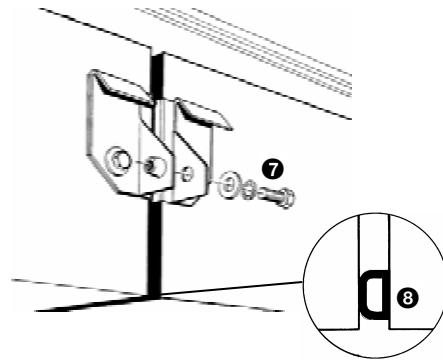

- 5 Interlink the modules ⑦.



Caution:

When linking the modules, do not fully press the rubber seal ⑧ together.

Ensure that the air valve module, if any, is attached to the roof or wall duct in a draught-free manner.

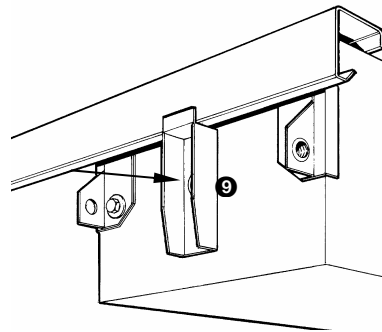

- 6 Re-attach the securing bracket ⑨, which was removed in step 1, to the relevant module(s).



Warning:

Make sure that the module(s) is (are) secured. Unsecured suspension may lead to a module falling out of the suspension structure.

2.7 Connecting the valve motor

Accessory with air valve module (PS L)

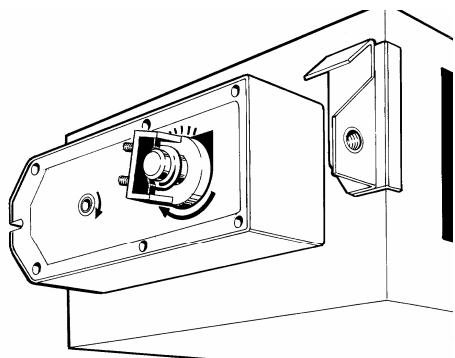

The air valve module is available with a pre-mounted valve motor. If the module does not yet have a valve motor, you must mount it first.

- 1 Both the valve motor and the base module have a cable with a connector. Connect these.
- 2 You may want to set a stop to the valve motor.

This allows you to open the air valve partially, so the unit will ventilate and recirculate at the same time.

2.8 Connecting ducts

Only with plenum PS P or duct connections PS TH and PS TV

The plenum module **PS P** (illustrated) allows the modular fan coil unit to be connected, via circular Ø 200 mm ducts, to a discharge or intake opening.

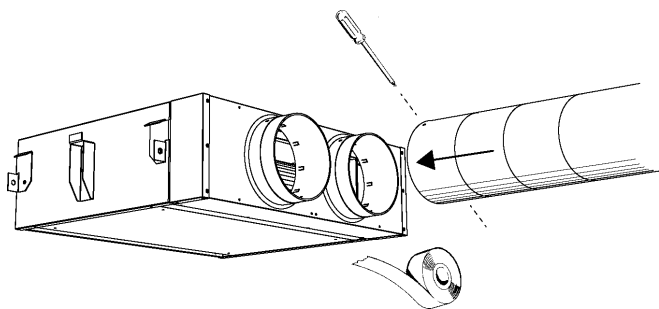

Connection through rectangular ducts is possible with the duct connections **PS TH** and **PS TV**, using flexible connection sleeves (not illustrated).

Mounting the ducts depends on the local situation, and is to be carried out according to your own judgment. However, follow the below instructions in order not to affect the unit's performance:

- Avoid any abrupt duct transitions.
- Keep ducts as short as possible.
- Mount flexible connection sleeves to the intake opening under slight tension (this is to prevent the connection sleeve from being sucked to a close at high fan speeds).
- Provide for proper sealing at transitions in the duct system.

2.9 Connecting the unit to the CH and/or CW system

Only for units with water heating and/or cooling

2.9.1 Water connections

Depending on the type, the connections have female-thread fittings or compression fittings.

The heat exchanger may come with pre-mounted control valves. If so, the CH and/or CW pipes are to be connected to them.

The connections are marked with arrows that indicate either supply or return: with heating, the arrows are red; with cooling, blue.

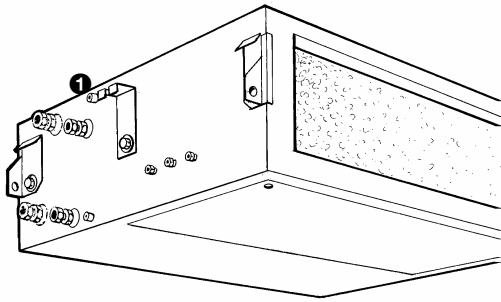

The (1/8") vent cocks ❶ are mounted to the collectors of the heat exchanger, protruding from the side of the module.



Caution:

Biddle recommends the inclusion of a valve in each pipe.

Operating pressure for CH and CW systems

	temperature	maximum operating pressure
screwed fittings	< 20° C	16 bar
	< 93° C	10 bar
	< 110° C	6 bar
compression fittings	all	3 bar

2.9.2 Frost protection

Only for units with ventilation

Depending on the control system, the unit has a frost protection thermostat or a controller-integrated protection.



Caution:

This reduces the risk of the heat exchanger freezing but does not warrant 100% protection.

Prevent the heat exchanger from freezing:

- Provide for constant circulation of the water at the right temperature.
- Add glycol to the water when the unit is not in operation during the wintertime.

2.9.3 Connecting water pipes

- 1 Lay the water pipes, and connect them to the screwed or compression fittings.



Caution:

Tighten the compression fittings well.

- 2 Fill the CH and/or CW system.
- 3 Vent the heat exchanger.
- 4 Check the connections for leaks.

2.10 Connecting the condensate drain

Only for units with cooling

2.10.1 Particulars

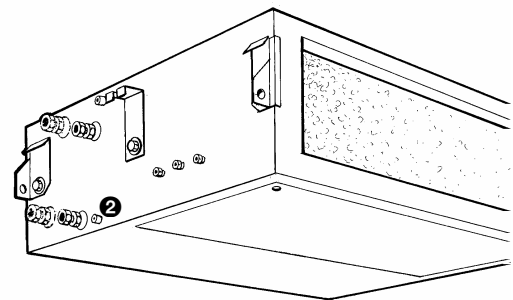

The unit has two (Ø 15mm) condensate water drains ❷. One of the drains must be fitted with a stink trap and connected to the sewer. The second drain is closed with a compression cap but can be used if necessary.

The unit can be provided with a condensate drain tray and/or a condensate pump (accessories). If so, their drains must be connected.

2.10.2 Connecting the condensate drain

- 1 Install a sewer connection incl. stink trap.
- 2 Connect the condensate drain tray to a flexible hose.
- 3 Connect the hose, with a stink trap, to the sewer.
- 4 Insulate the pipes that are not hanging over the condensate drain tray.

2.11 Connecting the unit to mains power supply

2.11.1 General



Warning:

The unit must be earthed.

The unit must be connected in accordance with all applicable local laws and regulations.



Caution:

Do **not** switch the unit on and off with the mains switch but rather with the controller.

2.11.2 Connecting to mains

For units with water heating and/or cooling:

- 1 Install an earthed wall socket at no more than 1.5m from the connection side of the base module.



Caution:

Do not yet insert the plug into the wall socket.

For electrically heated units:

- 1 Install an all-pole switch with a minimum contact distance of 3 mm.
- 2 Connect the switch to the mains.



Warning:

Make sure that the mains supply group is switched off.

- 3 Connect the unit to the switch according to the wiring diagram.



Caution:

Do **not** yet switch the mains supply group on!

2.12 Installing the controller

Depending on the type, the unit can be fitted with an electronic controller. Install it according to the respective manual.

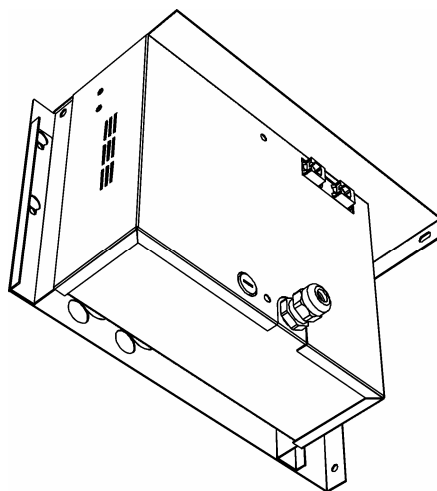

The connections are located on the electronics compartment or on the control unit's PCB in the compartment (see Section 4.2.2).

2.13 Switching on and checking operation

For all units:

- 1 Check if all modules are correctly suspended and secured.
- 2 Check the order of installation of the modules (see Section 1.3.3).
- 3 Check the connection to the mains.
- 4 Check the controller connections (see the corresponding documentation).
- 5 Switch on the mains supply.
- 6 Make the controller ready for use according to the appropriate manual.
- 7 Switch on the unit using the controller. Check whether the unit blows out air.

For units with water heating and/or cooling:

Check if the heat exchanger is properly connected:

- 8 Make sure the CH and/or CW system is (are) switched on.

- 9 Let the unit heat and/or cool using the controller. Feel whether the discharged air is getting hot (if heating) or cold (if cooling).
- 10 Vent the heat exchangers if necessary.

For units with cooling and condensate discharge pump (accessory):

Check the working of the condensate discharge pump:

- 11 Pour water into the external drip tray. The condensate pump should start working shortly.

For units with air valve module:

- 12 Check the seal of the fresh air duct: it should be draught-free.
- 13 Check whether the air valve closes off the ventilation opening properly in both modes.
- 14 Let the unit ventilate and recirculate using the controller. Check whether the air valve moves to the right position.

For units with an air valve module featuring a valve motor with spring return:

- 15 Switch off the mains power supply and check whether the valve automatically closes the duct.
- 16 Switch on the mains supply and check whether the valve works normally again.

3 Maintenance

3.1 Safety instructions



Warning:

Maintenance works may be performed by qualified technical staff only.

Before opening the unit, follow the safety instructions in Section 1.5.

3.2 Replacing the filter

3.2.1 Introduction

The filter must be replaced regularly. A dirty filter may cause inadequate heating, cooling or ventilation as well as a high noise level. The interval at which the filter is to be replaced depends on the use of the room.

New filters are available from Biddle. You may also clean the filter material with, for instance, a vacuum cleaner. After some cleanings, however, the filter must be replaced.

3.2.2 Replacing flat-bed filter in base module

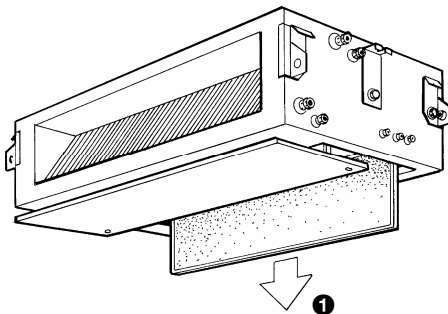

- 1 Remove the inspection panel from the base module (Section 4.2.1).
- 2 Gently pull ❶ the frame and the filter material out of the unit. If you handle the filter too roughly, dust may fall out.
- 3 Replace the filter with a filter of the same class.

3.2.3 Replacing bag-type filter or pleated filter

Only for filter module PS F or PS FE

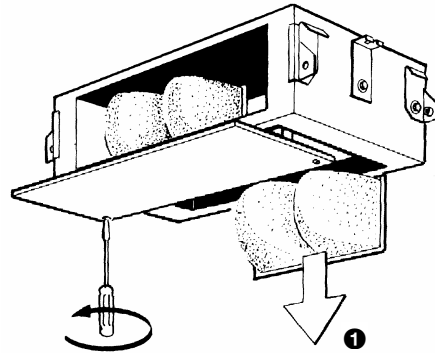

- 1 Remove the inspection panel from the filter module (Section 4.2.1).
- 2 Gently pull ❶ the cassettes and the filter material out of the unit. If you handle the cassettes too roughly, dust may fall out.
- 3 Replace the cassettes with cassettes of the same filter class.

3.3 Cleaning

You can clean the unit's exterior as well as the air intake and discharge grilles with water and a domestic cleaning agent. Do not use any solvents.



Warning:

Make sure no water enters the unit.

Carefully remove dust from the heating element with a vacuum cleaner.

3.4 Scheduled maintenance

Biddle recommends to have the following inspections performed by an installer or other technical expert every year.

For all units:

- Check if the filter is clean enough, and undamaged. Replace the filter if necessary.

- Check the air intake and discharge grilles for contamination and clean them if necessary.
- Check the heating elements and the fans for dust and other contaminants. Clean them if necessary.
- Check the working of the fan.

For units with water heating and/or cooling:

- Check for water leaks. If there is a leak, disconnect the unit from the mains, and repair the leak.
- Check if the water circuit contains any entrapped air. If yes, vent the circuit.

For units with cooling:

- Check if the condensate drain and condensate tray (accessories) are clean. Contamination may lead to poor drainage and to growth of bacteria and fungi.
- Clean the filter of any condensate pump (accessory) in the float module.

For units with air valve module:

- Check if the ventilation valve closes properly in both modes.
- Check if the valve closes automatically if the power supply is interrupted.

4 Service

4.1 Safety instructions



Warning:

Service work on the unit may be performed by qualified technical staff only.

Before opening the unit, follow the safety instructions in Section 1.5.

4.2 Opening the unit

4.2.1 Base module

The base module houses:

- the fan;
- the heat exchanger;
- the transformer with fuse (in some types).

Remove the inspection panel from the base module to access these components:

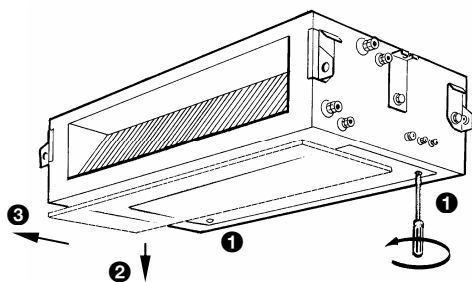

- 1 Turn the two quarter-turn fasteners ❶.
- 2 Pull ❷ the inspection panel about 3 cm down.
- 3 Slide ❸ the panel towards the discharge opening.

You may want to remove the inspection panel in its entirety:

- 4 Position the panel diagonally in the opening, and remove it from the module.

4.2.2 Electronics compartment

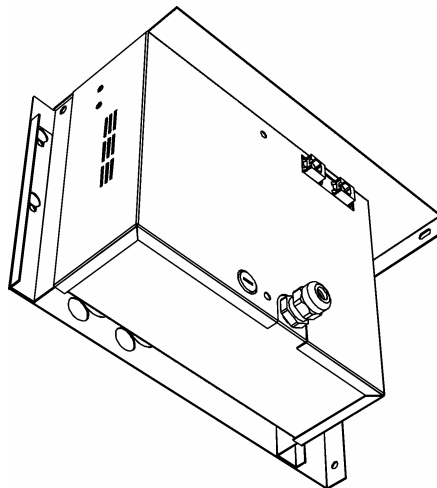

The electronics compartment is located on the side of the base module. It contains:

- the PCB and the electronic control connections;
- the transformer with fuse (in some types).

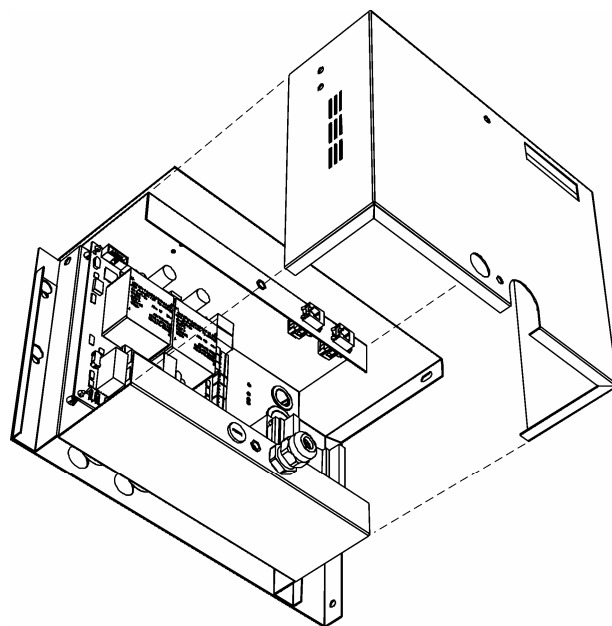

Remove the cover from the electronics compartment to access the PCB.

4.3 Fuses

The fuse rating is indicated near the fuse holder.

Location of fuses

unit type	fuse holder	
	transformer	control
control M or S with capacity 20, 21, 40 or 60	on electronics compartment	no individual fuse
control M or S with capacity 41 or 61	on electronics compartment and in base module (near transformer)	no individual fuse
control I	on electronics compartment	on PCB
control B	in base mod- ule (near transformer)	<i>not applicable</i>

- 2 Press the knob on the side of the base module or heating module.

4.4 High-limit thermostat

For base module or electric heating module

The unit is protected with a high-limit thermostat. When the heating elements reach a too high temperature, the high-limit thermostat will switch off the electric heating for safety reasons. You can switch the heating on again by resetting the high-limit thermostat.



Warning:

If the high-limit thermostat is activated frequently, there may be a dangerous defect. In that case, disconnect the unit from the mains and consult Biddle.

The high-limit thermostat may also be activated when power is supplied to the unit after a power failure.

To reset the high-limit thermostat:

- 1 Allow the unit to cool down.

Declaration of Conformity

manufacturer: Biddle BV
address: Markowei 4
9288 HA Kootsterille
The Netherlands

We declare that the following product:

product description: Modular Fan Coil Unit
brand: Biddle
model: PS
type: PS-20/21/40/41/60/61

In accordance with the following Directives:

2006/95/EC the Low Voltage Directive
2006/42/EC the Machinery Directive
2004/108/EC the Electromagnetic Compatibility Directive

Has been designed and manufactured to the following specifications:

EN 61000-6-2 Electromagnetic Compatibility (EMC) -- Part 6-1: Generic standards – Immunity for industrial environments
EN 61000-6-3 Electromagnetic Compatibility (EMC) -- Part 6-3: Generic standards – Emission standard for residential, commercial and light-industrial environments
EN 60335-1 Safety of household and similar electrical appliances Part 1: General requirements
EN 60335-2-30 Safety of household and similar electrical appliances Part 2-30: Particular requirements for room heaters

I hereby declare that the equipment named above has been designed to comply with the relevant sections of the above referenced specifications. The unit complies with all essential requirements of the directives.

signed by: W. de Vries, Managing Director, 2012

